



PEPS Version 2026 Innovations

PEPS Version 2026

Innovations

Table of contents

Common Functions

- 3 Workspace
- 3 Origins

CAD Data Import

- 4 Complete revision
- 4 CAD interfaces

Wire EDM

- 5 Billet Dialog
- 5 Ruled Surface Machining
- 5 Edit/ Transfer NC Data Dialog
- 5 Collecting information during postprocessor run
- 5 Progress bar

WIRE-Expert

- 6 Converter options

Postprocessors: Wire EDM

- 6 AC CUT UNIQUA
- 7 AC Vision
- 7 Makino
- 7 Sodick
- 7 Fanuc
- 7 Start hole Postprocessors

Milling

- 8 Setup
- 8 Edit/ Transfer NC Data

Toolpath Calculation:

3D / 5 Axis

- 8 Operations
- 8 New buttons
- 8 Graphical display
- 9 Workspace
- 9 Error Messages
- 9 Automatic Stock Tracking

3D Milling

- 10 Offset Roughing
- 10 3D Roughing
- 11 Offset/ Parallel Roughing
- 11 Roughing
- 11 Adaptive Roughing
- 12 Finishing Strategies
- 13 Constant Z
- 13 Combined Constant Z + Constant Cusp
- 13 Flatland
- 14 Constant Cusp
- 14 Containment curves
- 14 Corner Finishing
- 15 Pencil Machining

5 Axis Simultaneous Milling

- 16 Multi axis finishing
- 16 Multi axis roughing/ Rest material Roughing
- 16 Multi axis roughing
- 17 Deburring
- 17 SWARF Machining
- 18 Geodesic Machining
- 19 Rotary Machining Roughing
- 19 Rotary Machining

Milling

- 20 Simulation

Postprocessors: Milling

- 20 Sinumerik 840D

2D Laser Cutting

- 20 "Edit/ Transfer NC Files" Dialog
- 20 "Module Settings" Dialog

CUT-Expert:

3D Laser- & Waterjet Cutting

- 21 Micro-Joints
- 21 Dialog for Change Points (NCI)
- 21 New Lead in/ Lead out Strategy
- 21 "Module Settings Dialog"
- 21 Tube Cutting

Turning

- 22 General
- 22 Operation Manager
- 22 Editor
- 22 Simulation
- 22 Definition of working planes

CAMMAN 10.0

- 23 Program Management

PEPS Version 2026 Innovations

Common Functions

Workspace

If 3D models interfere with an **element selection**, you can **exclude** them from the element selection using the **Skip Body** function.

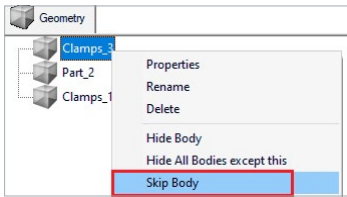

The **Workspace** has been expanded to include the **“Origin”** tab. The new tab clearly summarizes the functions for **managing** and **editing “Origins”**.

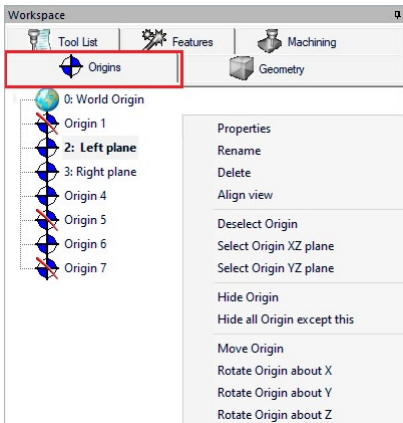

Origins

The context menu (right mouse button) for **“Origins”** has been expanded and reorganized.

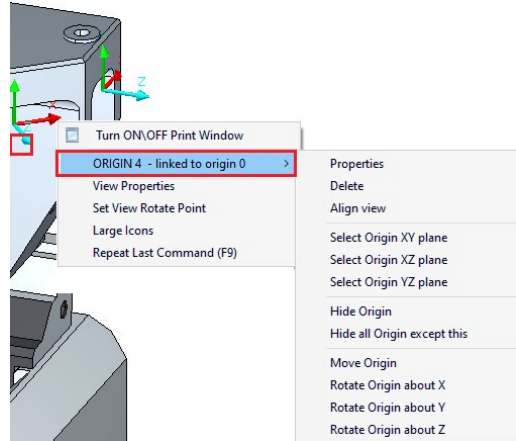

Starting with PEPS Version 2026, it will be possible to supplement the **Origin** with a **descriptive text**.



Individual Origins and **the associated geometric objects** can be shown or hidden.

PEPS Version 2026 Innovations

CAD Data Import

Complete revision

To **speed up** CAD data import and make it **even more secure**, the CAD interfaces have been fundamentally revised, expanded, and modernized. As an interim solution, the **Settings** dialog for CAD data import has been expanded to include **additional import variants**:

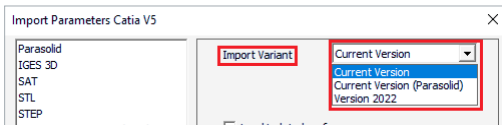

There are three import options available:

- **Current version:** Import using the latest interface technology (recommended)
- **Current version (Parasolid):** Import using the latest interface technology (uses alternative conversion method).
- **Version 2022:** Import using the proven import technology of the previous version (note: Direct interfaces NX, CATIA, Creo, etc. are not currently available here).

CAD interfaces

The following CAD interfaces have been updated:

- INVENTOR – Version 2026
- CatiaV5 R35
- CatiaV6 R2025
- Siemens NX – Continuous Release 2506
- SOLIDWORKS Version 2026
- Solid Edge Version 2026
- ACIS/SAT 33
- CREO 13
- IGES 5.3
- JT 10.9
- Parasolid/XT 38.0
- STEP 242
- VDA 2.0

PEPS Version 2026 Innovations

Wire EDM

Billet Dialog

The dialog for defining Billets has been expanded.

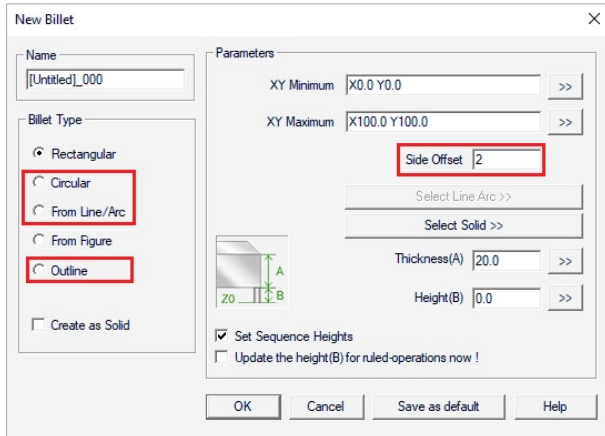

- **Circular:** Derive Billet and Height from a model edge
- **From Line/arc:** Derive Billet and Height from model edges or lines/arcs
- **Outline:** Derive Billet and Height by projecting the 3D model outer contour
- **Side Offset:** From PEPS Version 2026 onwards, all Billet types allow the specification of a circumferential oversize/undersize.

Ruled Surface Machining

The “**Ruled Surface > Lead**” dialog has been expanded to include the “**Extend**” option. It is now possible to extend the toolpath of ‘open’ **Ruled Surface** machining operations.

This function eliminates the need for geometric extension of the **upper/lower** Profile figures in order to extend the toolpath of “open” **Ruled Surface** machining operations.

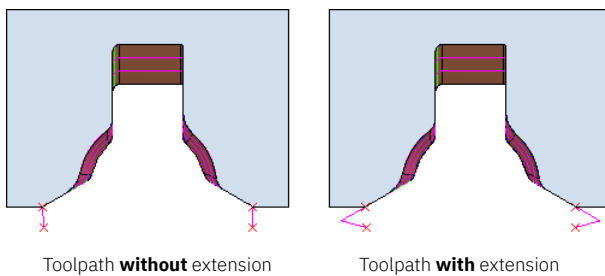

Edit / Transfer NC Data Dialog

The **Edit/Transfer NC Data** dialog has been revised and expanded. **The icons in the user interface** have been updated and a **new icon (1) for opening the NC directory** has been added. The new info **window (2)** displays additional information about the current NC program, such as machining time and length of the machining paths.

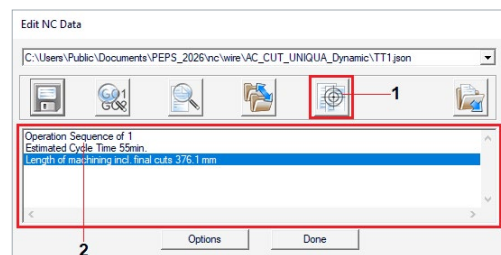

Collecting information during postprocessor run

It is now possible to “collect” information during a postprocessor run. This information is stored in the *.VDM file and can be displayed at any time (**without** running the postprocessor). In addition, new options have been added to the “**Module Settings**” dialog:

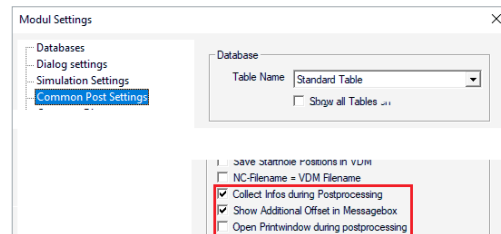

The collected information is displayed when you use the **Edit / Transfer NC Data** dialog.

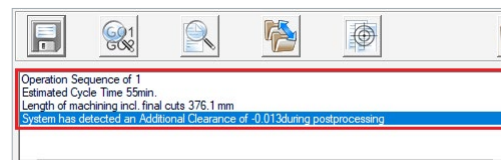

This usually eliminates the need to open the “**Print**” window to display the **machining time**, for example.

Progress bar

During a **postprocessor run**, a **progress bar** is now displayed for **all** postprocessors.

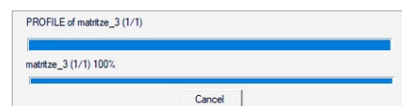

PEPS Version 2026 Innovations

WIRE-Expert

Converter options

The **WIRE-Expert > Configure Wire-Expert Parameters** dialog has been expanded to include the option **Merge repeated figures rather than splitting into separate jobs**. The new option **combines the geometries of identical Ruled Surfaces** and creates **a single machining operation** instead of creating an operation for each Ruled Surface.

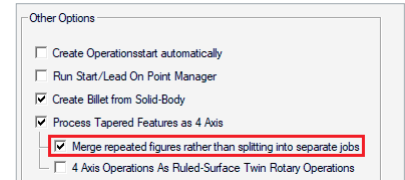

Postprocessors: Wire EDM

AC CUT UNIQUA

“Dynamic“

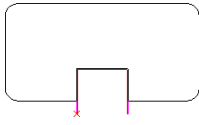
- Straight, extended Lead on and Lead off** is now also possible for “open” contours. 
- Technology Version 2.8.7 ManVersion 1.5.0 BuildNo 25199:** PEPS Version 2026 supports the latest UNIQUA firmware version (10/2025).
- Negate Additional Clearance:** Until now, users had to specify the **sign** for the **Additional Clearance** in the UNIQUA “**Dynamic**” postprocessor **reversed** (+ instead of -) as usual. With the **new postprocessor** setting, this change in thinking is no longer necessary and the behavior is **identical for all postprocessors**.

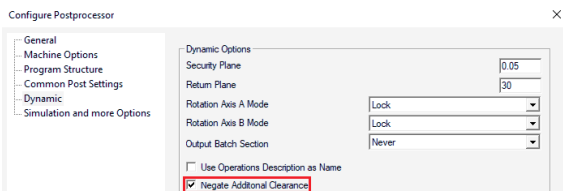

“Sequential“

- Measure cycles added:** Measure cycles have been implemented for the UNIQUA Sequential.
- “Sequential“ Version 2.8.7 ManVersion 1.5.0 BuildNo 25199:** PEPS Version 2026 supports the latest UNIQUA firmware version (10/2025).

“Dynamic“ and “Sequential“

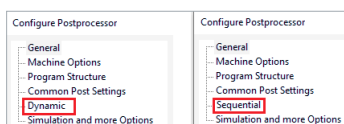

The pages in the **Postprocessor Settings** dialog have been reorganized. There is now a separate dialog for the **UNIQUA Dynamic** and **Sequential** postprocessors.

“Change Technology“ button redesigned

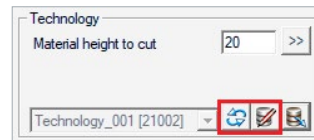

The behavior of the **Change Technology** button has been revised for the **UNIQUA Dynamic** and **Sequential** machine types.



The button now allows you to **adjust** the technology currently used in the dialog without having to load a new technology.



If the adjusted technology is to be used by other existing operations, the relevant operations must be edited once and then refreshed by clicking the **Update** button. Only then will the new values be used for these operations.

“Set Taper Flags“ from Database

In the **Module Settings** dialog, you can now specify whether the “**Apply Taper**” fields should be set or not when selecting a **technology** from the database.

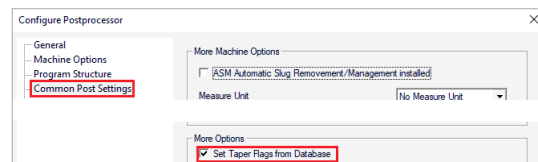

Cutting Setup		Cutting Setup	
Cut No.	Apply Taper	Cut No.	Apply Taper
1	<input checked="" type="checkbox"/>	1	<input type="checkbox"/>
2	<input checked="" type="checkbox"/>	2	<input type="checkbox"/>
3	<input checked="" type="checkbox"/>	3	<input type="checkbox"/>
4	<input type="checkbox"/>	4	<input type="checkbox"/>

Left: If the option “**Set Taper Flags from database**” not activated, the fields “**Apply Taper**” retain their current status.

Right: If the option is activated and the selected technology contains **no Taper information**, the fields “**Apply Taper**” are deactivated.

PEPS Version 2026 Innovations

AC CUT UNIQUA

New NC Code Viewer for *.JSON files

The “**JSON Viewer**” was developed to display NC data in ***.JSON** format in a **structured and easily readable** manner. The viewer can be called up **after** a postprocessor run in the “**Edit/Transfer NC Files**” dialog:

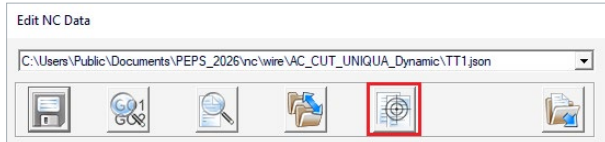

New NC Code Viewer for *.JSON files

AC Vision

“Offset Geometry” output now possible in combination with User Technology

The NC output has been optimized for the combination of **AC Vision Technology Database** plus the **Offset Geometry** option. In the above case, only an unedited **copy** of the Technology used needs to be created on the machine as **User Technology**. The “**Offset values**” in this **user technology** are automatically set to **zero** when used.

Negate Additional Clearance

Until now, users had to specify the **sign** for the **Additional Clearance** in the **ACVISION** postprocessor **reversed** (+ instead of -) as usual. With the new **Postprocessor Setting**, this change in thinking is no longer necessary and the behavior is **identical for all postprocessors**.

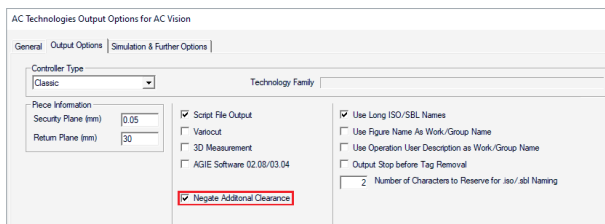

Measure Cycles revised

New, revised Measure Cycles have been developed for the AC Vision postprocessor.

Makino

The dialog for Importing Technologies has been improved and updated. New, revised Measure Cycles.

Sodick

New, revised Measure Cycles.

Fanuc

New, revised Measure Cycles.

Start hole Postprocessors

The **Start hole Postprocessors** now allow you to specify a **Reference Point**.

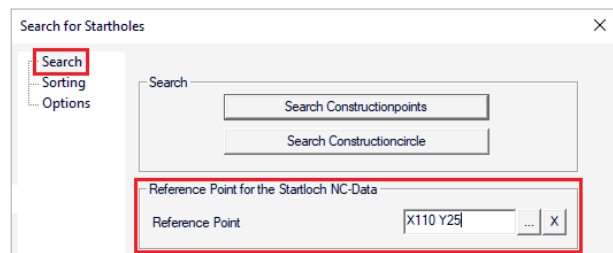

The Reference Point is displayed **symbolically** in the graphics window.

PEPS Version 2026 Innovations

Milling

Setup

The **Setup** dialog has been completely redesigned, expanded, and modernized.

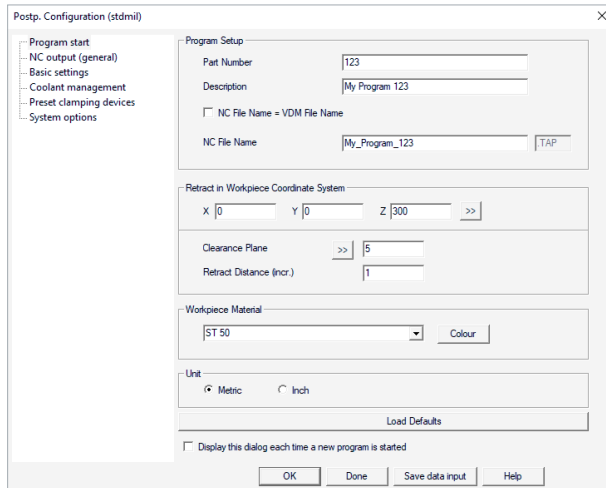

Edit / Transfer NC Data

The **icons** in the **User Interface** have been updated and a **new icon for opening the NC directory** has been added.

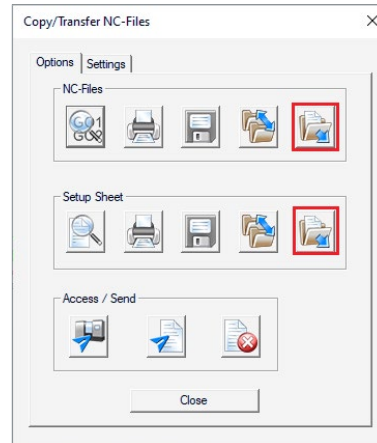

Toolpath Calculation: 3D / 5 Axis

Operations

The Toolpath Calculation for 3D and 5 axis operations has been completely revised. The following new options are available:

Calculate “Automatically” or “On Demand”

Starting with PEPS Version 2026, you can choose whether operations are calculated immediately or at a later time:

- **Automatically:** Toolpaths are calculated immediately.
- **On Demand:** Toolpaths are calculated later in the Workspace, e.g., by selecting the status display.

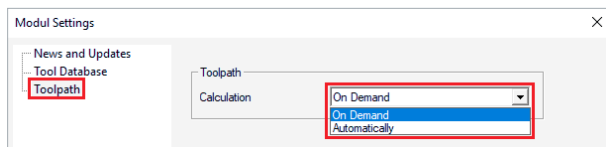

The required option can be set in the Module Settings dialog.



New buttons

From PEPS Version 2026 onwards, **3D and 5 axis** operations can also be calculated **outside** the dialogs.

To calculate the tool paths, use:

-  **Workspace:**
The status display
-  **Context menu:**
Option Recalculate operation(s)

Multiple selection of operations is permitted.

Graphical display

If you recalculate a toolpath **within** a machining dialog, the corresponding **Toolpath is immediately updated**. It is no longer necessary to close the dialog.

PEPS Version 2026 Innovations

Workspace

Status display

The **status display** before processing operations has been revised.

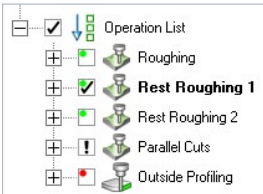

Exclamation mark: Toolpath has not been calculated

Green light: Toolpath has been calculated

Green traffic light with check mark: Toolpath calculated and displayed

Yellow light: Toolpath calculation in progress

Red light: Error in Toolpath calculation

New status indicator “Not yet calculated”

An **exclamation mark** marks all **3D and 5 axis** operations that require a recalculation of the tool path.

Progress Indicator

During the **Toolpath Calculation**, the current **calculation progress in percent** is displayed in **front of the operation name**.

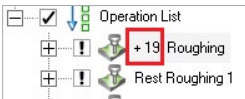

Error Messages

Error messages during the **calculation of tool paths** are now displayed as follows:

- The status display for the operation in question switches to red .
- Double-clicking on the operation opens the dialog and displays a red error message.
- A single click on the status display only displays the red error text:

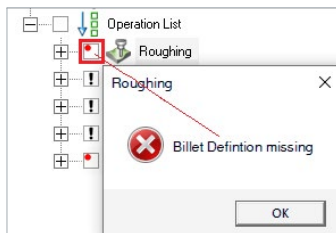

Automatic Stock Tracking

The new **“Automatic Stock tracking”** feature will be available from PEPS Version 2026 onwards. This opens up new possibilities, especially for **Roughing** operations that calculate material removal based on a **Stock body**. If the parameters of a Roughing operation change, the **Stock is virtually updated**. The system then **updates** all **subsequent operations** that use the Stock, either **automatically or manually**.

The options for **Stock** assignment have been expanded for the new **“Automatic Stock tracking”** feature.

In the **3D/5-axis** dialogs, a new **Stock Definition dialog** is used to specify the roughing operations for which **“Automatic Stock tracking”** is to be performed.

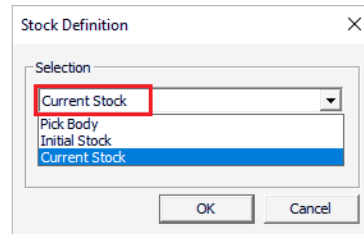

For **“Automatic Stock tracking,”** select the entry **Current Stock**.

Note:

You will find the new dialog in the **3D/5-axis** dialogs: **“Roughing” tab > Stock Definition > Stock surfaces**

PEPS Version 2026 Innovations

3D Milling

Offset Roughing

“Arc-Line-Arc” Links for Offset Roughing (... Link > Groups > Within Group)

The new **Arc-Line-Arc** Links for **Offset Roughing** generates smooth, efficient transitions within a slice layer while maintaining a safe distance from the outer boundary of the part, reducing the overall machining time.

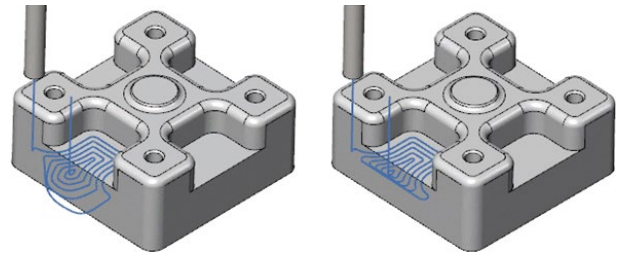

Blend Spline left

Arc-Line-Arc left

3D Roughing

Taper Helical Ramp

This feature creates a **taper helical ramp** which ensures better chip evacuation and significantly enhances tool life for Roughing operations.

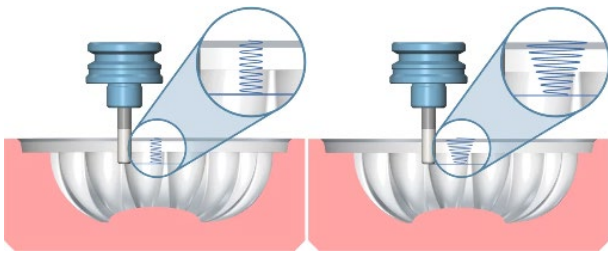

Taper Helical Ramp **Off**

Taper Helical Ramp **On**

Spindle Speed for Ramps

This feature enables **spindle speed adjustments** during ramping motions, improving tool reliability and performance when plunging into hard materials.

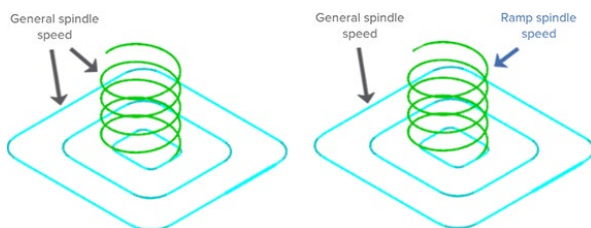

Enhanced “Air Move Safety Distance”

This feature improves the control of retract link clearances by making the **Air move safety distance** compatible with the **Optimize lead and link distances** option, ensuring safer and more efficient toolpath transitions.

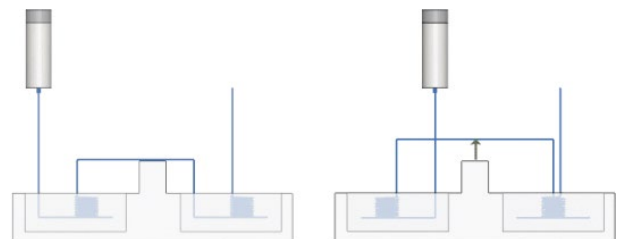

Before

After

PEPS Version 2026 Innovations

Offset / Parallel Roughing

New “Within Group Size” option

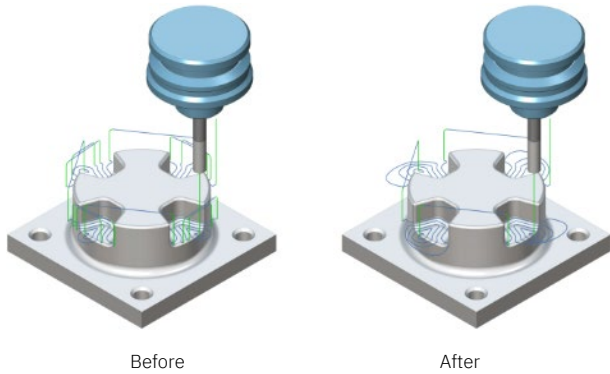

Frequent and unnecessary tool retracts can disrupt machining efficiency and increase cycle times. By providing control over the “area links” length, this feature keeps the tool at the current slice level for longer, enhancing flexibility and minimizing unwanted retractions. The current hardcoded limitation restricting within – **Group Link Distances** up to twice the tool diameter – forces unnecessary tool retractions during machining. This leads to inefficient tool movement and increased cycle times. A new **Within Group Size** parameter specifies the maximum allowable distance between the start and end points of adjacent roughing toolpath cuts. This new feature allows users to customize the conditions for creating **direct** and **blend spline links**, keeping the tool at the slice level whenever possible. This provides greater machining flexibility and eliminates undesired tool retractions.

Adaptive Roughing

Thin Wall Avoidance

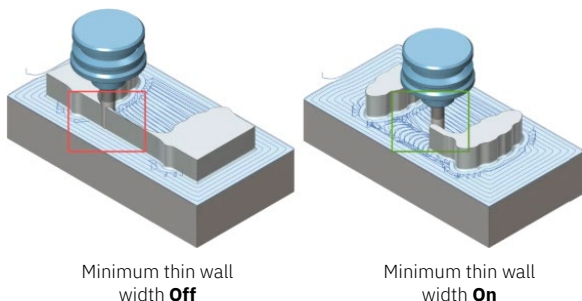

This option lets you control the **minimum stock wall** thickness. When the tool breaks through the remaining stock wall, all subsequent machining is performed with optimal tool engagement.

Roughing

Improved “Avoid Air Machining” Algorithm

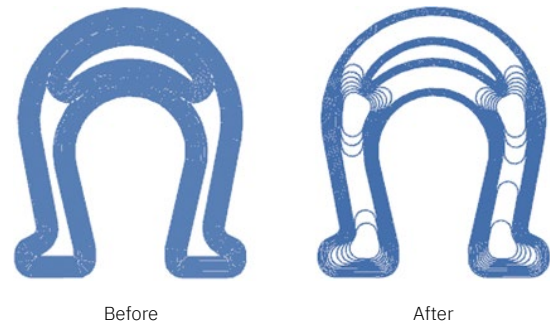

The enhanced **Avoid air machining** logic uses advanced detection of overlapping tool coverage areas to significantly reduce unnecessary tool movements in empty regions and improve machining efficiency.

Ramp Height Control
Inside Pre-drill Hole

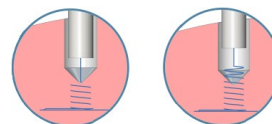

Air cuts and unsafe tool approaches in pre-drilled holes increase machining time and risk tool damage. This feature optimizes the ramp height based on the drill tip angle, ensuring safe entry, eliminating air cuts and improving efficiency.

Large Diameter Helical
Ramp Support

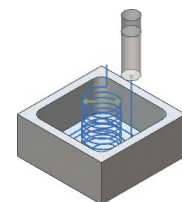

This feature enables the creation of helical ramps with diameters larger than the tool itself, offering greater flexibility when machining soft or composite materials.

PEPS Version 2026 Innovations

Finishing Strategies

Links > Links Between Regions

Previously, this feature was limited to Constant Z patterns and did not include other finishing cycles. An additional linking option for regions has been added for **all finishing cycles** other than **Project curves**, including Constant Z > 3-Axis Undercut machining. This is providing more refined control over the linking behavior. With this feature, users can easily handle complex linking scenarios without compromising on efficiency.

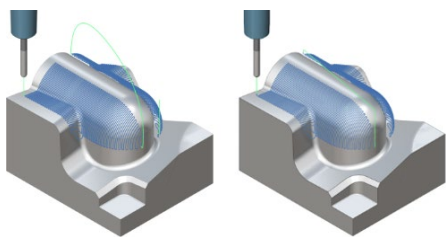

Blend spline connection

Clearance move connection

“Invert area”

Previously, flipping the cutting area was time consuming and tedious because users had to manually change the containment direction. Now, with the **Containment > 3D > Invert area** option, swapping between areas is quick and simple, making the process more convenient and efficient.

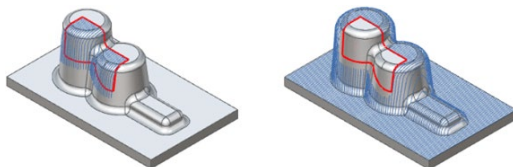

Invert Area **Off**

Invert Area **On**

Contact Point Boundary from 3D Model

Previously, setting a **Contact point boundary** was time-consuming and error-prone, as there was no way to extract it within the dialog directly from a **3D Model**. Now, the ability to extract a Containment within the dialog **directly from a 3D Model** makes the selection easier and reduces the overall programming effort. This new feature makes programming more convenient and consistent.

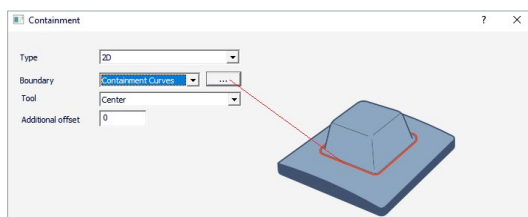

Avoid “Edge Rolling”

This enhancement improves the handling of sharp edges in machining strategies such as **Constant Z, Parallel Cuts, Constant Cusp and Project Curves**. It also extends edge rolling suppression to **3D Contact Point Boundary** toolpaths, ensuring that sharp edges are preserved and not unintentionally machined over.

This improvement helps maintain the integrity of sharp edges where they are functionally required, resulting in better part quality and precision. It reduces the risk of unwanted edge rounding and supports consistent, high-quality Mold and Die production.

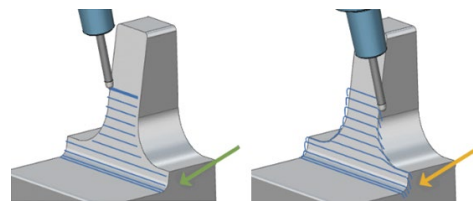

Edge rolling **Off**

Edge rolling **On**

Rest Finishing based on Tool Length

A common challenge in machining is reaching areas limited by the tool stick-out length. The feature **Rest finishing > based on > Tool length** overcomes that by splitting the toolpath into zones based on the different stick out lengths of the tools, allowing optimal speeds and feeds for each region and improving surface quality.

This feature enhances the quality of the machined part while significantly reducing programming time.

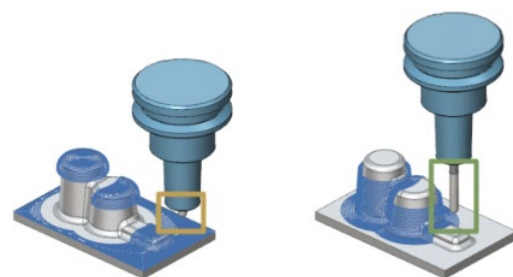

Initial operation

Rest finishing based on tool length

PEPS Version 2026 Innovations

Constant Z

Blend Along Distance for Constant Z and Combo Cycles

The new **Blend along distance** option has been introduced for **spiral** toolpaths. It can be used for all **Constant Z** related patterns, including hybrid strategies, to ensure smooth transition moves.

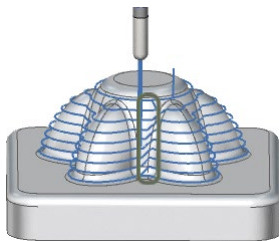

Combined Constant Z + Constant Cusp

Remove Corner Pegs

This new feature adds peg loops at the relevant points to reinforce the corners, ensuring uniform surface quality and reducing manual labor. By targeting the corners, it ensures uniform toolpath patterns during machining.

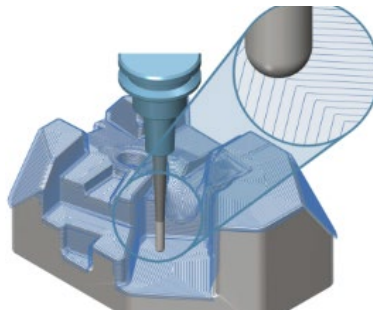

Corner peg removal **Off**

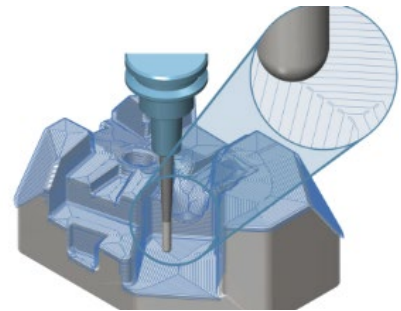

Corner peg removal **On**

Flatland

Automatic 3+2 Flatland Finishing

A new option automatically detects flatlands and determines the optimal machining direction - all in a single operation. With this new feature, users easily generate toolpaths for machining flatlands in significantly less time. The automated process streamlines the workflow and ensures consistent part quality.

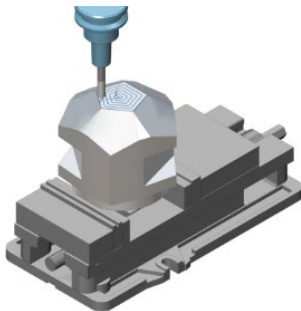

Flatlands 3+2 **Off**

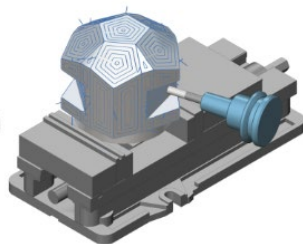

Flatlands 3+2 **On**

Fixture Awareness for Flatland Machining

This reduces programming time, increases usability and results in safer machining. This new feature enables users to define and include the fixtures in **Flatland** toolpaths. As a result, fixtures can be recognized and avoided to prevent collisions. This reduces programming time, increases usability and results in safer machining.

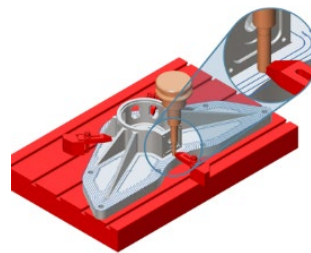

Fixture Awareness **Off**

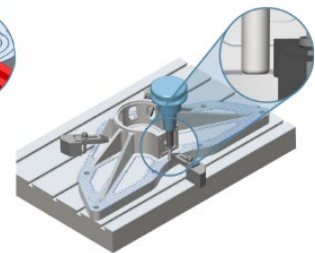

Fixture Awareness **On**

PEPS Version 2026 Innovations

Constant Cusp

Deviation for Containment Cuts

Previously, using the **Constant Cusp** strategy it was difficult to clear all material when the option for rounded corners on the toolpath was active because it also applied to cuts on the containment. To address this, a deviation setting has been introduced specifically for containment passes, allowing effective removal of the leftover material and enhancing overall part quality. This enhancement improves surface quality and gives users the flexibility to remove excess material within the same operation.

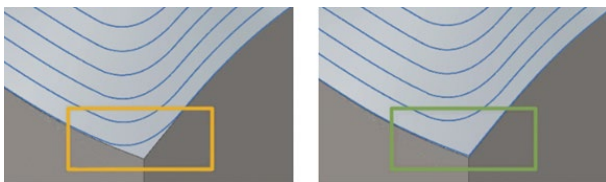

Containment deviation **Off**

Containment deviation **On**

Containment curves

Previously, only a projected 2D offset was available, and the actual offset on the part was largely influenced by the part topology. With the new feature **Surface-Paths > Containment > Type > 3D Offset**, an equidistant offset from the containment along the part surfaces is now possible, enabling users to extend the machining area in a more controlled manner.

3D Offset for Containment generates an offset along the part, providing greater control over the offset results.

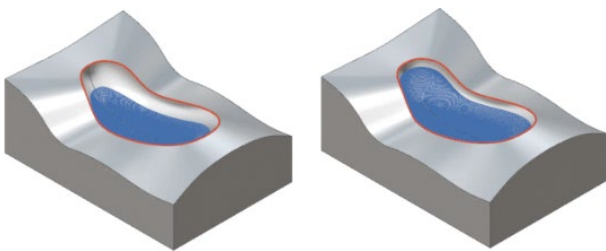

2D Offset

3D Offset

Corner Refinement

The **Constant Cusp** strategy often produced inconsistent results for corners in the pattern, leading to uneven surface quality. With this enhancement, it is now possible to achieve consistent cut patterns, even in the corners. This new feature achieves a superior surface quality without compromising the stepover or cut tolerance, thereby eliminating the need to compensate for inaccuracies in the toolpath pattern.

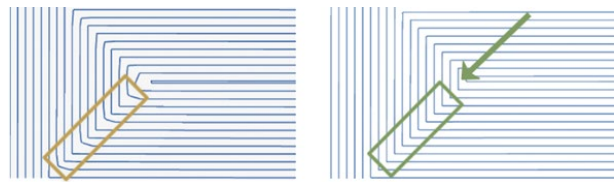

Corner refinement **Off**

Corner refinement **On**

Corner Finishing

One of the challenges in 3-axis mold and die processing is safely and effectively removing all material from inner corners, as optimal stick-out lengths and small diameters demand ideal cutting conditions to ensure optimal dimensional accuracy and surface finish while also avoiding tool breakages. The new Corner Finishing option with smaller tools solves this, enabling the creation of high-quality molds and dies.

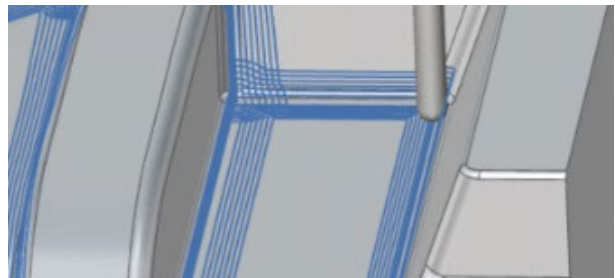

The **new machining strategy** gives users a dedicated corner finishing option for efficiently machining inner corners, helping to safely and effectively remove all material and improve the surface quality of the finished part, thereby reducing the need for subsequent hand processing.

Note: Available approx. 03.2026

PEPS Version 2026 Innovations

Pencil Machining

Fixture Awareness for Pencil Machining Link Between Regions

This new feature enables users to define and include the fixtures in **Pencil** toolpaths. As a result, fixtures can be recognized and avoided to prevent collisions. This reduces programming time, increases usability and ensures safer machining.

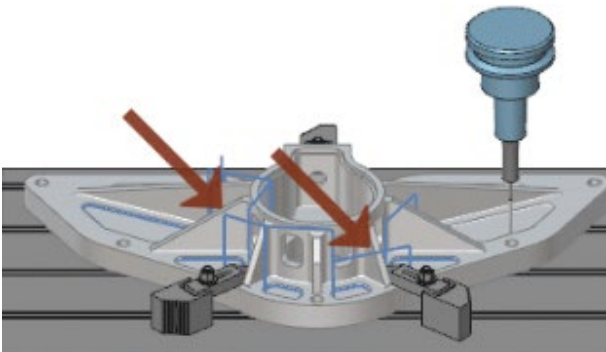

Fixtures avoided

“Overthickness” Option added

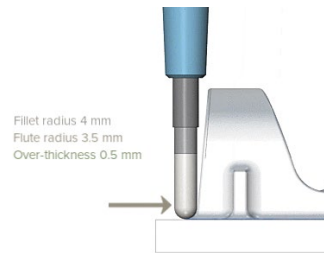

Fillets that are too large for the selected tool could be missed during detection.

To prevent this, a **virtual Overthickness** is added on both sides of the tool and corner detection is performed

using this oversized tool model. This approach ensures more fillets are detected and prevents toolpath fragmentation.

With this new feature, fillets are detected and machined more consistently, tool changes are minimized, and overall machining time is reduced.

PEPS Version 2026 Innovations

5 Axis Simultaneous Milling

Multi axis finishing

Bull Nose Tool support for Wall, Floor & Rest Finishing

Bull nose tools can be used in **Multi axis finishing** operations, making it easier to perform final finishing. This feature improves surface finish, reduces tool changes and enhances overall efficiency.

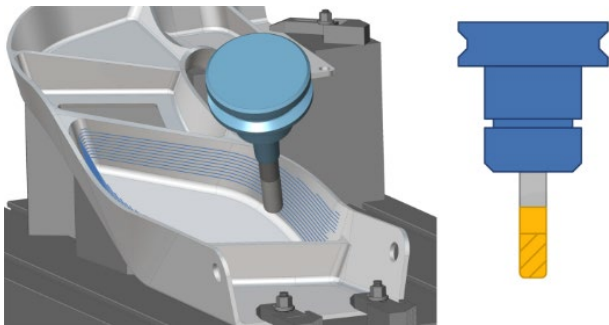

Bull nose tool support for wall finishing

Improved Rest Finishing for Wall, Floor and Rest Finishing

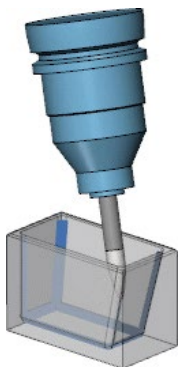

Until now, rest areas left after 5-axis finishing could not be efficiently machined, especially after Wall and Floor Finishing. Now, advanced algorithms allow these rest areas to be finished easily and effectively.

The new version improves the efficiency of rest finishing complex contours and areas by automating the cumbersome post-processing steps.

Multi axis roughing/Rest material Roughing

Finishing revised and improved

The functions for **Rest material detection** and **machining** have been revised and improved for the **Multiaxis Roughing/Finishing** strategies.

Multi axis roughing

Cusp Removal After Helical Ramping

After helical ramping, **cusps were visible** in the center of helices that were wide relative to the tool diameter. This new feature adds an **extra pass over the center** of the helix to remove those cusps.

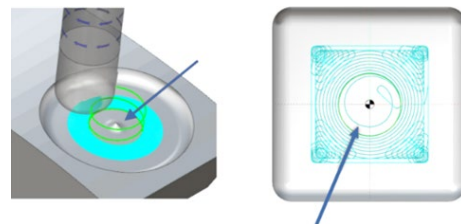

Extra spiral move

Rapid Traverse for Connection Links

This feature adds a rapid traverse to all the connection links between adjacent retract/approach moves. It applies to retractions on feeds and rapid and clearance distances.

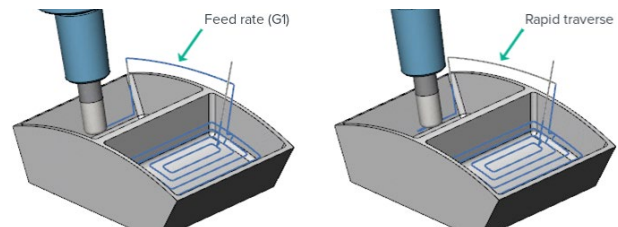

Rapid traverse **Off**

Rapid traverse **On**

Engagement Control for Intermediate Slices

This feature introduces precise engagement control for intermediate slices during adaptive roughing operations. It suppresses the unnecessary toolpath segments that result from minimal material removal, particularly in the inner corners and on fine geometrical features.

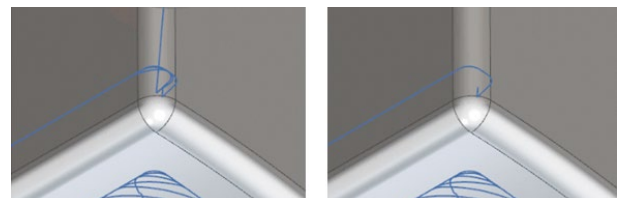

Maximum stepover **Off**

Maximum stepover **On**

PEPS Version 2026 Innovations

Deburring

Automatic Machining Direction

This feature automatically finds the machining direction based on the contour definition. A new option called **Automatic machining direction** takes the contour direction into account to ensure optimal ordering. This feature makes toolpath deburring more user-friendly, while also reducing the machining cycle time.

Skip Circular Holes and Vertical Edges

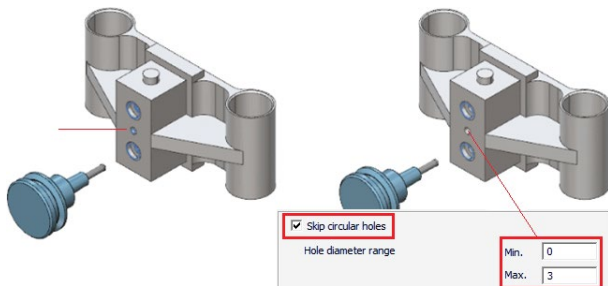

Manually selecting different hole **types** and **vertical edges** in 3-axis machining can be time-consuming and error-prone.

Two new options optimize the process by allowing the user to:

- Exclude specific holes (Option: Skip circular holes – Diameter ran from min. D to max. D)
- Or filter out and isolate vertical edges (Option: Skip vertical edges).

Both options make the selection of **holes** and vertical **edges** faster, more accurate, and more efficient.

SWARF Machining

Input Automatization

Previously, SWARF Machining required input geometry with sharp-cornered surfaces, limiting the feature's flexibility. This restriction has now been removed, allowing more versatile surface handling and enhanced support for complex geometries.

With this improvement, SWARF Machining can automatically detect guide curves on surfaces with rounded corners, significantly accelerating programming and increasing adaptability across a broader range of part topologies.

User Defined Edge Sequence

This feature helps users to select edges for machining in their preferred sequence, providing greater flexibility during the deburring process. As an **alternative to automatic sorting**, the **input order** of the included curves **can now be preserved** and the resulting toolpath is sorted accordingly. This allows users to define the sequence in which edges are machined.

Use “Double Chamfer Tool” for Deburring

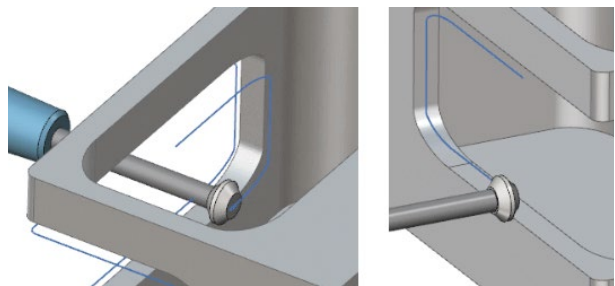

This release introduces a **double chamfer tool** for deburring. Now it is possible to deburr both the upper and lower edges of a part using a double chamfer tool. The system automatically chooses whether to apply the tool's upper or lower chamfer to each contour.

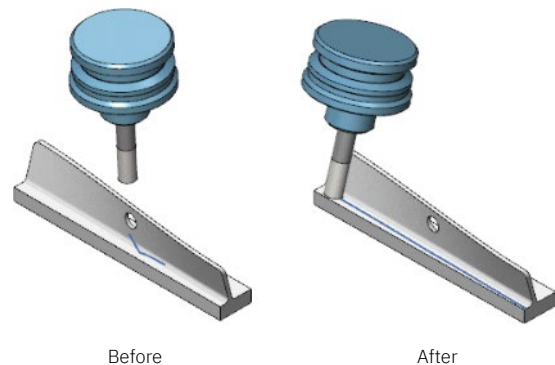

PEPS Version 2026 Innovations

Geodesic Machining

Morph Between Multiple Curves (more than two curves)

Geodesic now supports a sequence of morph operations within a single toolpath, allowing users to create smooth, continuous patterns across complex surfaces.

This enhancement consolidates multiple morph operations into one, enabling seamless transitions across different areas of the part while maintaining pattern quality.

The result is faster programming, smoother toolpath patterns, and support for efficient cutting methods like spiral machining.

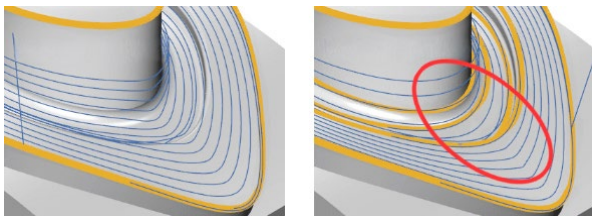

2 Morph curves

6 Morph curves

Morph Pattern – Support for smoothed toolpath

Rough or abrupt transitions in morph toolpaths can compromise surface quality and machining consistency.

With **smoothed support curves** activated, the system creates a significantly smoother morph pattern, enhancing surface finish and delivering more fluid, reliable machine movements.

This new feature iteratively generates smoothed support curves between morph curves prior to pattern generation, resulting in a smoother final morph pattern. With this feature, users can improve surface quality and reduce machining time.

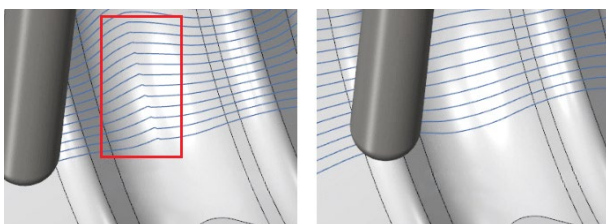

Smoothed Support Curves **Off**

Smoothed Support Curves **On**

Part Awareness for Pattern Generation

The **entire part** can now be processed using the **Geodesic pattern**, taking the entire machining surface into consideration. As a result, fewer cuts need to be trimmed by collision control, reducing unnecessary toolpath modifications caused by potential collisions.

The updated Geodesic **Tool Center** mode now supports full part geometry input, enabling the generation of **collision-free** toolpaths for the **spherical tool** tip. This applies exclusively to cutting motions of the spherical tip; linking movements and the tool body are not included. To ensure complete safety, users must enable **collision control** to guarantee a collision-free path for the **entire tool body**. Additionally, users can define extra clearance values relative to the part surfaces for enhanced control and safety.

Together with collision control, this feature delivers more natural, collision-free toolpaths, minimizes manual setup and enhances overall machining safety.

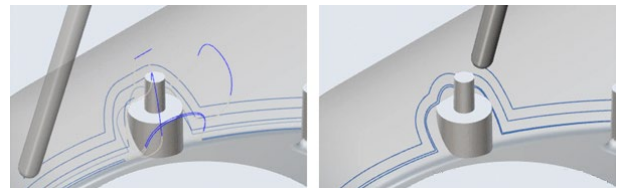

Part Surfaces **Off**

Part Surfaces **On**

PEPS Version 2026 Innovations

Rotary Machining Roughing

Remove Corner Pegs

This enhancement modifies the **rotary roughing** toolpath to eliminate uncut material, known as corner pegs, that are left behind in tight corners due to large stepover values.

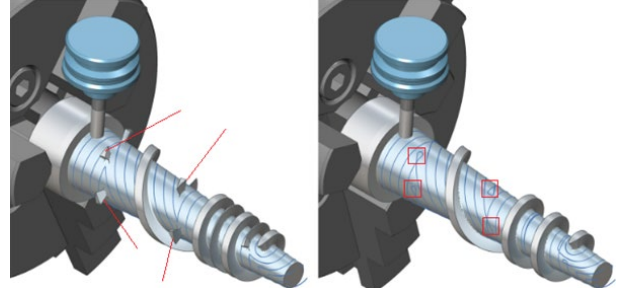

Remove Corner Pegs **Off**

Remove Corner Pegs **On**

Rotary Machining

Cone Angle Normal to Conical Surface

This new feature **Cone Angle Normal to Conical** detects and applies toolpaths on conical floors without tilting the milling head, providing greater flexibility and precision during rotary finishing.

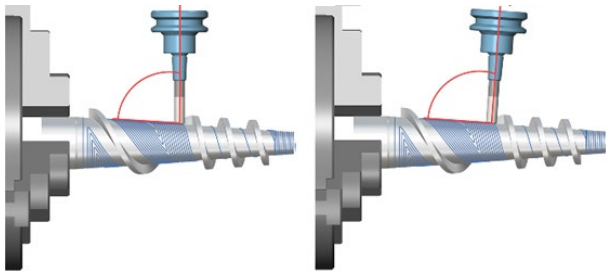

Normal to Conical Surface **Off**

Normal to Conical Surface **On**

Finishing - Offset and Spiral Strategy

Rotary finishing now supports a hybrid offset and spiral cutting method for cylindrical and conical surfaces, automatically selecting the optimal strategy based on machining conditions.

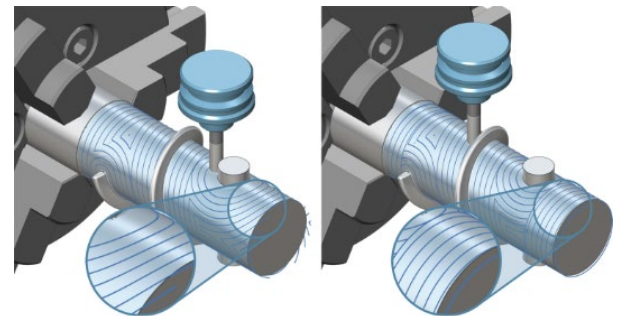

Offset

Offset and Spiral

PEPS Version 2026 Innovations

Milling

Simulation

Enhance Accuracy Checkbox for Cutting and Collision Checking in Material Mode

We have introduced a new experimental checkbox in the Options menu called **“Improve cutting and collision checking accuracy in Material Mode”**. This feature enhances the precision of cutting and collision checks in Material Mode, particularly in scenarios involving upper

parts of the cutting tool or other elements of long tools cutting or approaching the stock material.

Note:

This feature should only be enabled when higher accuracy is required, as it may slow down the simulation.

Postprocessors: Milling

Sinumerik 840D

Complete revision

A new, revised **Postprocessor** has been introduced for machines with **Sinumerik 840D** control. The postprocessor replaces the existing postprocessor and supports the latest functionalities and setting parameters of the **Sinumerik 840D** control.

New Dialog for “Postprocessor Settings”

A new **“Postprocessor Settings”** dialog has been developed for the **Sinumerik 840D** postprocessor.

The dialog features new, expanded setting options that allow users to configure the postprocessor themselves to a large extent.

2D Laser Cutting

“Edit / Transfer NC Files” Dialog

User Interface revised

The **icons in the user interface** have been updated and a **new icon for opening the NC directory** has been added.

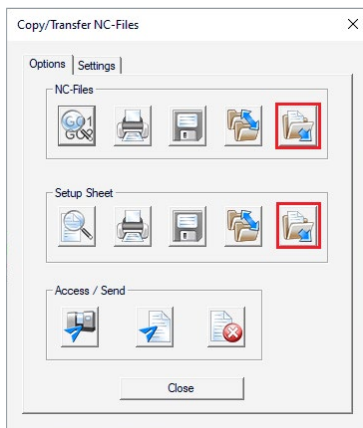

“Module Settings” Dialog

Path specification for storing the Setup Sheet adjustable

It is now possible to **specify your own path** for storing the setup sheet (*.PDF file). The path specification overwrites the default path specification.



PEPS Version 2026 Innovations

CUT-Expert: 3D Laser- & Waterjet Cutting

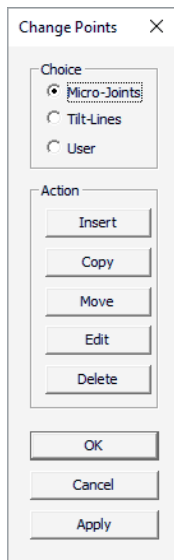

Micro-Joints

Micro-Joints can also be edited retrospectively from PEPS Version 2026 onwards.

Dialog for Change Points (NCI)

The dialog for defining and manipulating **Change Points** (e.g., Micro-Joints, Tilt-Lines, etc.) has been fundamentally revised:

New Lead in/ Lead out Strategy

The Lead in/Lead out strategy has been expanded to include the **“Mould” strategy**. This strategy removes waste material by cutting a Mould-shaped indentation.

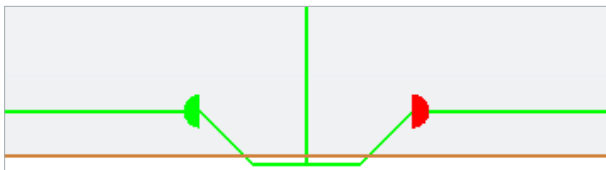

New Lead in/Lead out strategy **Mould**

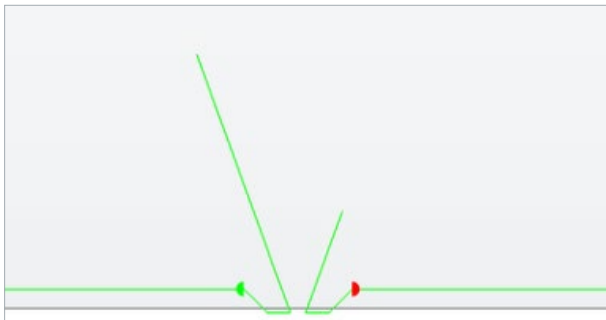

The mould can also be used in conjunction with micro joints and multiple Micro joints.

“Module Settings Dialog”

Path specification for storing the Setup Sheet adjustable

It is now possible to **specify your own path** for storing the setup sheet (*.PDF file). The path specification overwrites the default path specification.

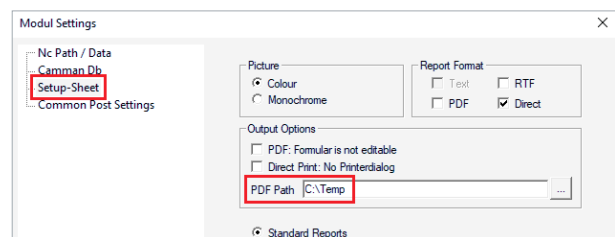

Tube Cutting

Show Tube Box

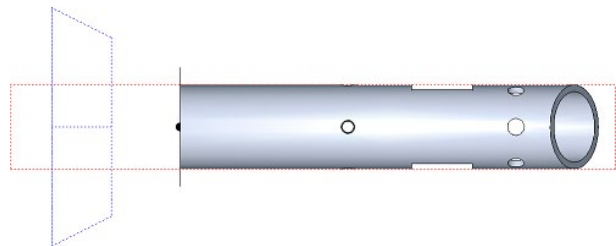

The new function displays a **red, dashed graphic** of the Stock box. The position of the chuck is shown in **blue**. The zero point position defined by the user is shown in **black**.

“Tube parameters” dialog revised

The **“Tube parameters”** dialog has been moved from **Settings** to **Objects**.

New **“Clamping length of Pipe”** parameter introduced.

New **“Automatically generate Stock”** function. The function automatically determines the tube cross-section and generates the Stock graphic from it.

“Rotary cutting” cutting strategy is supported

When this new cutting strategy is used, the workpiece rotates and the material is removed laterally around the circumference.

“Tube repositioning” function now supported

The new function allows long Tubes to be **repositioned**.

PEPS Version 2026 Innovations

Turning

General

General corrections and bug fixes for drilling operations in the **Turning module**.

Operation Manager

Simulation in the Operation Manager:

Tool alignment via direction vector.

Editor

Starting with PEPS Version 2026, the G-code editor supports the entry of special commands and marks commands that are not recognized by the syntax check in red.

```
MES (Aussen SR)
SetWS (1)
WZBK ; Aufruf der WBZK.SPF (Werkzeugbruchkontrolle)
G0 Z1.0
G0 X87.0
G0 X83.2 Z1.8
G1 Z0.431 F0.3
G1 X84.732 Z-0.334
G3 X85.2 Z-0.9 CR=0.8
G1 Z-457.9
G1 X86.126 Z-458.136
G1 X87.0
G1 X91.0 Z-456.136
G0 X87.0 Z1.0
G0 X200.0 M9
G0 Z300.0
```

The special commands are transferred to the NC program but do not interfere with the simulation.

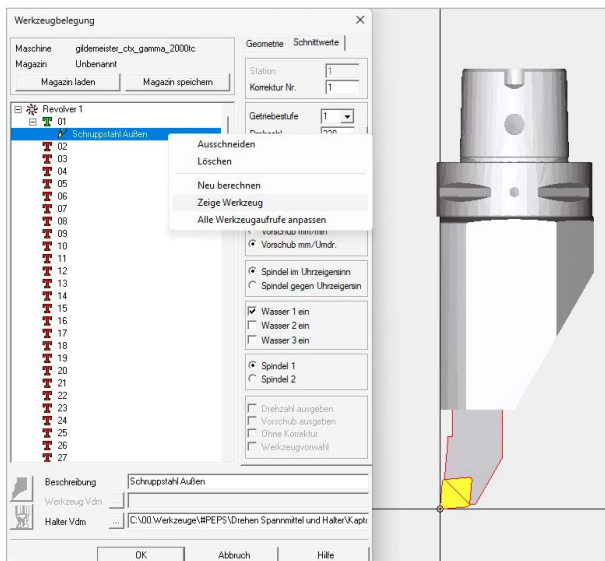

The tool assignment has been expanded to include the Show Tool function.

Simulation

- New “Simulate operation” function in the right-click context menu when selecting an operation.
- When using the “Simulate operation” function, tools are displayed as 3D models with holders

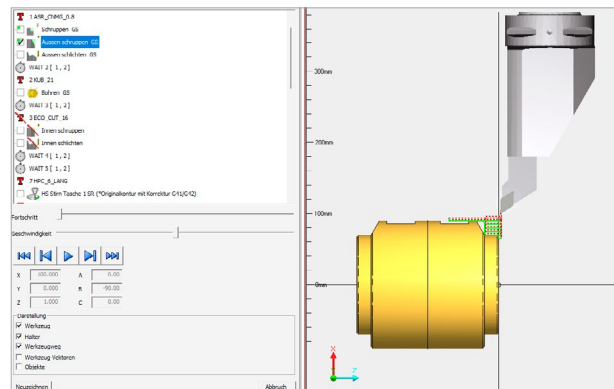
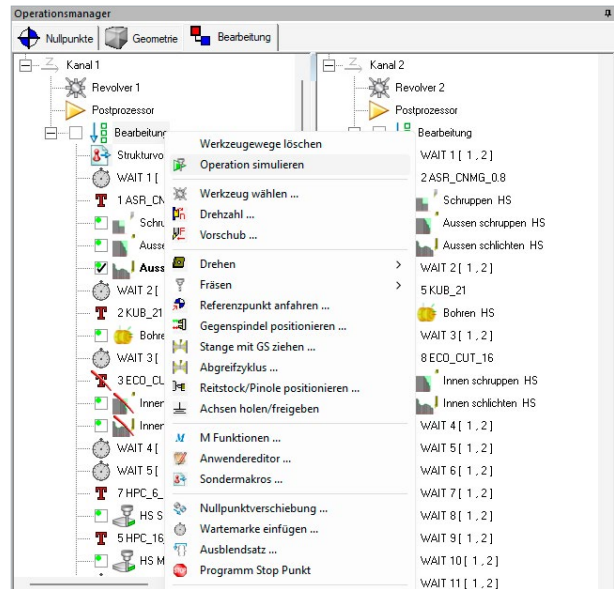

Definition of working planes

Improvements in the selection and NC output of zero points (working planes)

PEPS Version 2026 Innovations

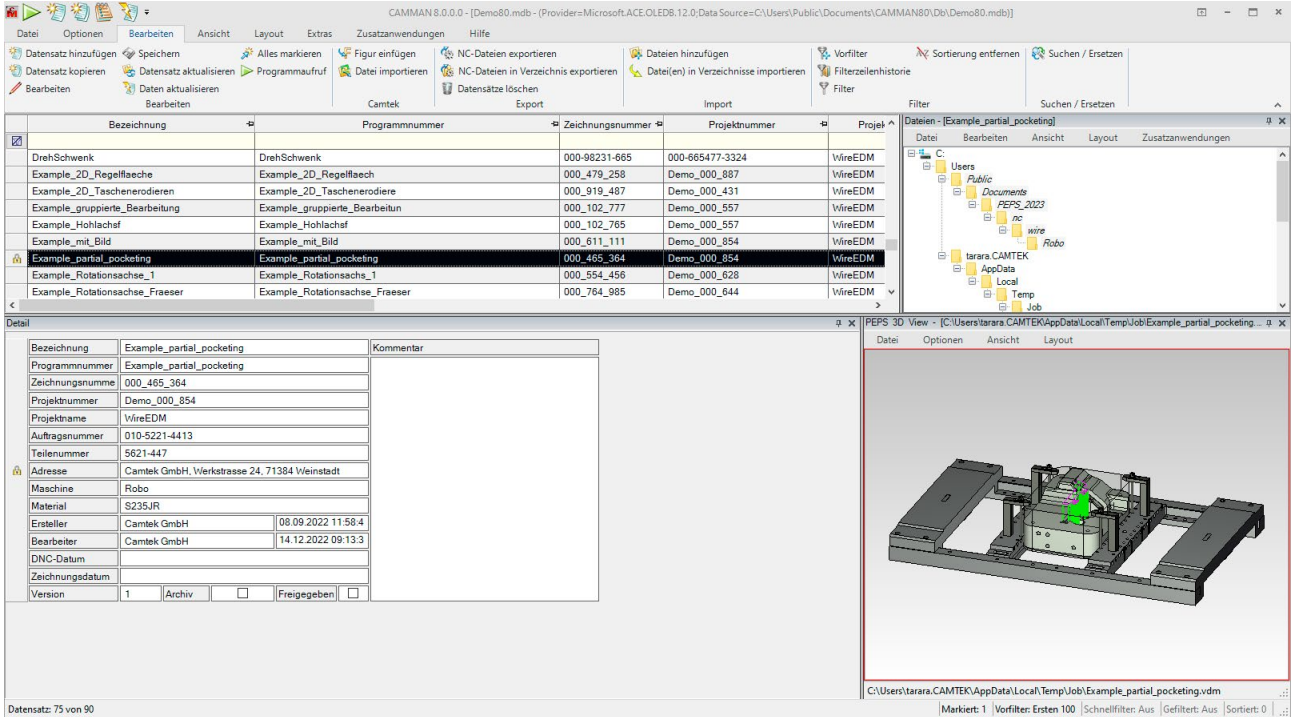

CAMMAN 10.0

Program Management

CAMMAN 10.0 has been specially adapted for the latest version of MS Windows 11 and PEPS Version 2026.

Note:
CAMMAN 10.0 is required for PEPS Version 2026.